



IEEE

IEC 63055

Edition 2.0 2023-09

INTERNATIONAL IEEE Std 2401™ STANDARD



Format for LSI-Package-Board Interoperable design –

INTERNATIONAL
ELECTROTECHNICAL
COMMISSION

ICS 31.180, 31.200, 35.060

ISBN 978-2-8322-7515-3

Warning! Make sure that you obtained this publication from an authorized distributor.

Contents

1. Overview	11
1.1 Scope	11
1.2 Purpose	11
1.3 Key characteristics of the LSI-Package-Board Format	11
1.4 Contents of this standard	12
1.5 Word usage	13
2. Normative references	13
3. Definitions, acronyms, and abbreviations	13
3.1 Definitions	13
3.2 Acronyms and abbreviations	16
4. Concept of the LPB Format	18
4.1 Technical background	18
4.2 Conventional design	18
4.3 Common problems at the design site	19
4.4 Concept of LPB interoperable design	19
4.5 Value creation by LPB interoperable design	19
4.6 LPB Format	21
4.7 Summary of LPB Format files	21
5. Language basics	27
5.1 General	27
5.2 Typographic and syntax conventions	27
5.3 Character information	28
5.4 Notation of the floating point number	28
5.5 File naming definitions	28
6. Common elements in M-Format, C-Format, and R-Format	29
6.1 General	29
6.2 The <extensions> element	29
6.3 The <header> element	30
6.4 The <global> element	32
7. M-Format	48
7.1 M-Format file structure	48
7.2 The <include> element	49
7.3 The <current_phase> element	49
7.4 The <class> element	50
8. C-Format	56
8.1 C-Format file structure	56
8.2 The <module> element	56
8.3 The <component> element	161
9. R-Format	165
9.1 R-Format file structure	165
9.2 The <Physicaldesign> element	166
9.3 The <Constraintrule> element	201

10. N-Format	211
10.1 Purpose of the N-Format file	211
10.2 How to identify the power/ground network	211
10.3 Example	212
11. G-Format	212
11.1 Language basics of G-Format	212
11.2 Structure	213
11.3 Header section	214
11.4 Material section	215
11.5 Layer section	215
11.6 Shape section	216
11.7 Board geometry section	220
11.8 Padstack section	221
11.9 Part section	222
11.10 Component section	224
11.11 Net attribute section	225
11.12 Netlist section	225
11.13 Via section	227
11.14 Bondwire section	228
11.15 Route section	229
Annex A (informative) Bibliography	233
Annex B (informative) Examples of utilization	235
B.1 Understanding the function of the LPB Format	235
B.2 Test bench	235
B.3 Design flow example	237
B.4 Growth of the sample files in the LPB Format	269
B.5 Simulations using the sample files in the LPB Format	273
Annex C (informative) XML Encryption	275
Annex D (informative) MD5 checksum	278
Annex E (informative) Chip-Package Interface Protocol	279
E.1 General	279
E.2 Comparison of C-Format with Chip-Package Interface Protocol	279
Annex F (informative) M-Format usage examples	284
F.1 General	284
F.2 Bundling files for a product	284
F.3 Bundling files for a library	285
F.4 Managing design versions using M-Format	287
Annex G (informative) Example of how to express the connector parts as terminals	288
G.1 General	288
Annex H (informative) Participants	292

FORMAT FOR LSI-PACKAGE-BOARD INTEROPERABLE DESIGN –

FOREWORD

- 1) The International Electrotechnical Commission (IEC) is a worldwide organization for standardization comprising all national electrotechnical committees (IEC National Committees). The object of IEC is to promote international co-operation on all questions concerning standardization in the electrical and electronic fields. To this end and in addition to other activities, IEC publishes International Standards, Technical Specifications, Technical Reports, Publicly Available Specifications (PAS) and Guides (hereafter referred to as "IEC document(s)"). Their preparation is entrusted to technical committees; any IEC National Committee interested in the subject dealt with may participate in this preparatory work. International, governmental and non-governmental organizations liaising with the IEC also participate in this preparation.

IEEE Standards documents are developed within IEEE Societies and Standards Coordinating Committees of the IEEE Standards Association (IEEE SA) Standards Board. IEEE develops its standards through a consensus development process, approved by the American National Standards Institute, which brings together volunteers representing varied viewpoints and interests to achieve the final product. Volunteers are not necessarily members of IEEE and serve without compensation. While IEEE administers the process and establishes rules to promote fairness in the consensus development process, IEEE does not independently evaluate, test, or verify the accuracy of any of the information contained in its standards. Use of IEEE Standards documents is wholly voluntary. *IEEE documents are made available for use subject to important notices and legal disclaimers (see <https://standards.ieee.org/ipr/disclaimers.html> for more information).*

IEC collaborates closely with IEEE in accordance with conditions determined by agreement between the two organizations. This Dual Logo International Standard was jointly developed by the IEC and IEEE under the terms of that agreement.

- 2) The formal decisions of IEC on technical matters express, as nearly as possible, an international consensus of opinion on the relevant subjects since each technical committee has representation from all interested IEC National Committees. The formal decisions of IEEE on technical matters, once consensus within IEEE Societies and Standards Coordinating Committees has been reached, is determined by a balanced ballot of materially interested parties who indicate interest in reviewing the proposed standard. Final approval of the IEEE standards document is given by the IEEE Standards Association (IEEE SA) Standards Board.
- 3) IEC/IEEE Publications have the form of recommendations for international use and are accepted by IEC National Committees/IEEE Societies in that sense. While all reasonable efforts are made to ensure that the technical content of IEC/IEEE Publications is accurate, IEC or IEEE cannot be held responsible for the way in which they are used or for any misinterpretation by any end user.
- 4) In order to promote international uniformity, IEC National Committees undertake to apply IEC Publications (including IEC/IEEE Publications) transparently to the maximum extent possible in their national and regional publications. Any divergence between any IEC/IEEE Publication and the corresponding national or regional publication shall be clearly indicated in the latter.
- 5) IEC and IEEE do not provide any attestation of conformity. Independent certification bodies provide conformity assessment services and, in some areas, access to IEC marks of conformity. IEC and IEEE are not responsible for any services carried out by independent certification bodies.
- 6) All users should ensure that they have the latest edition of this publication.
- 7) No liability shall attach to IEC or IEEE or their directors, employees, servants or agents including individual experts and members of technical committees and IEC National Committees, or volunteers of IEEE Societies and the Standards Coordinating Committees of the IEEE Standards Association (IEEE SA) Standards Board, for any personal injury, property damage or other damage of any nature whatsoever, whether direct or indirect, or for costs (including legal fees) and expenses arising out of the publication, use of, or reliance upon, this IEC/IEEE Publication or any other IEC or IEEE Publications.
- 8) Attention is drawn to the normative references cited in this publication. Use of the referenced publications is indispensable for the correct application of this publication.
- 9) Attention is drawn to the possibility that implementation of this IEC/IEEE Publication may require use of material covered by patent rights. By publication of this standard, no position is taken with respect to the existence or validity of any patent rights in connection therewith. IEC or IEEE shall not be held responsible for identifying Essential Patent Claims for which a license may be required, for conducting inquiries into the legal validity or scope of Patent Claims or determining whether any licensing terms or conditions provided in connection with submission of a Letter of Assurance, if any, or in any licensing agreements are reasonable or non-discriminatory. Users of this standard are expressly advised that determination of the validity of any patent rights, and the risk of infringement of such rights, is entirely their own responsibility.

IEC 63055/IEEE Std 2401 was processed through IEC technical committee 91: Electronics assembly technology, under the IEC/IEEE Dual Logo Agreement. It is an International Standard.

The text of this International Standard is based on the following documents:

IEEE Std	FDIS	Report on voting
2401 (2019)	91/1869/FDIS	91/1887/RVD

Full information on the voting for its approval can be found in the report on voting indicated in the above table.

The language used for the development of this International Standard is English.

The IEC Technical Committee and IEEE Technical Committee have decided that the contents of this document will remain unchanged until the stability date indicated on the IEC website under webstore.iec.ch in the data related to the specific document. At this date, the document will be

- reconfirmed,
- withdrawn, or
- revised.

IEEE Standard Format for LSI-Package-Board Interoperable Design

Developed by the

Design Automation Standards Committee
of the
IEEE Computer Society

Approved 7 November 2019

IEEE SA Standards Board

Copyrights and permissions

All figures in this standard are reprinted with permission from JEITA.¹

Abstract: A method is provided for specifying a common interoperable format for electronic systems design. The format provides a common way to specify information/data about the project management, netlists, components, design rules, and geometries used in the large-scale integration-package-board designs. The method provides the ability to make electronic systems a key consideration early in the design process; design tools can use it to seamlessly exchange information/data.

Keywords: common interoperable format, components, design analysis, design rules, geometries, IEEE 2401™, large-scale integration (LSI), netlists, packages for LSI circuits, printed circuit board, project management, Verilog-HDL

Important notices and disclaimers concerning IEEE Standards documents

IEEE documents are made available for use subject to important notices and legal disclaimers. These notices and disclaimers, or a reference to this page, appear in all standards and may be found under the heading “Important notices and disclaimers concerning IEEE standards documents.” They can also be obtained on request from IEEE or viewed at <http://standards.ieee.org/IPR/disclaimers.html>.

Notice and disclaimer of liability concerning the use of IEEE Standards documents

IEEE Standards documents (standards, recommended practices, and guides), both full-use and trial-use, are developed within IEEE Societies and the Standards Coordinating Committees of the IEEE Standards Association (“IEEE SA”) Standards Board. IEEE (“the Institute”) develops its standards through a consensus development process, approved by the American National Standards Institute (“ANSI”), which brings together volunteers representing varied viewpoints and interests to achieve the final product. IEEE Standards are documents developed through scientific, academic, and industry-based technical working groups. Volunteers in IEEE working groups are not necessarily members of the Institute and participate without compensation from IEEE. While IEEE administers the process and establishes rules to promote fairness in the consensus development process, IEEE does not independently evaluate, test, or verify the accuracy of any of the information or the soundness of any judgments contained in its standards.

IEEE Standards do not guarantee or ensure safety, security, health, or environmental protection, or ensure against interference with or from other devices or networks. Implementers and users of IEEE Standards documents are responsible for determining and complying with all appropriate safety, security, environmental, health, and interference protection practices and all applicable laws and regulations.

IEEE does not warrant or represent the accuracy or content of the material contained in its standards, and expressly disclaims all warranties (express, implied and statutory) not included in this or any other document relating to the standard, including, but not limited to, the warranties of: merchantability; fitness for a particular purpose; non-infringement; and quality, accuracy, effectiveness, currency, or completeness of material. In addition, IEEE disclaims any and all conditions relating to: results; and workmanlike effort. IEEE standards documents are supplied “AS IS” and “WITH ALL FAULTS.”

Use of an IEEE standard is wholly voluntary. The existence of an IEEE standard does not imply that there are no other ways to produce, test, measure, purchase, market, or provide other goods and services related to the scope of the IEEE standard. Furthermore, the viewpoint expressed at the time a standard is approved and issued is subject to change brought about through developments in the state of the art and comments received from users of the standard.

In publishing and making its standards available, IEEE is not suggesting or rendering professional or other services for, or on behalf of, any person or entity nor is IEEE undertaking to perform any duty owed by any other person or entity to another. Any person utilizing any IEEE Standards document, should rely upon his or her own independent judgment in the exercise of reasonable care in any given circumstances or, as appropriate, seek the advice of a competent professional in determining the appropriateness of a given IEEE standard.

IN NO EVENT SHALL IEEE BE LIABLE FOR ANY DIRECT, INDIRECT, INCIDENTAL, SPECIAL, EXEMPLARY, OR CONSEQUENTIAL DAMAGES (INCLUDING, BUT NOT LIMITED TO: PROCUREMENT OF SUBSTITUTE GOODS OR SERVICES; LOSS OF USE, DATA, OR PROFITS; OR BUSINESS INTERRUPTION) HOWEVER CAUSED AND ON ANY THEORY OF LIABILITY, WHETHER IN CONTRACT, STRICT LIABILITY, OR TORT (INCLUDING NEGLIGENCE OR OTHERWISE) ARISING IN ANY WAY OUT OF THE PUBLICATION, USE OF, OR RELIANCE UPON ANY STANDARD, EVEN IF ADVISED OF THE POSSIBILITY OF SUCH DAMAGE AND REGARDLESS OF WHETHER SUCH DAMAGE WAS FORESEEABLE.

Translations

The IEEE consensus development process involves the review of documents in English only. In the event that an IEEE standard is translated, only the English version published by IEEE should be considered the approved IEEE standard.

Official statements

A statement, written or oral, that is not processed in accordance with the IEEE SA Standards Board Operations Manual shall not be considered or inferred to be the official position of IEEE or any of its committees and shall not be considered to be, or be relied upon as, a formal position of IEEE. At lectures, symposia, seminars, or educational courses, an individual presenting information on IEEE standards shall make it clear that his or her views should be considered the personal views of that individual rather than the formal position of IEEE.

Comments on standards

Comments for revision of IEEE Standards documents are welcome from any interested party, regardless of membership affiliation with IEEE. However, IEEE does not provide consulting information or advice pertaining to IEEE Standards documents. Suggestions for changes in documents should be in the form of a proposed change of text, together with appropriate supporting comments. Since IEEE standards represent a consensus of concerned interests, it is important that any responses to comments and questions also receive the concurrence of a balance of interests. For this reason, IEEE and the members of its societies and Standards Coordinating Committees are not able to provide an instant response to comments or questions except in those cases where the matter has previously been addressed. For the same reason, IEEE does not respond to interpretation requests. Any person who would like to participate in revisions to an IEEE standard is welcome to join the relevant IEEE working group.

Comments on standards should be submitted to the following address:

Secretary, IEEE SA Standards Board
445 Hoes Lane
Piscataway, NJ 08854 USA

Laws and regulations

Users of IEEE Standards documents should consult all applicable laws and regulations. Compliance with the provisions of any IEEE Standards document does not imply compliance to any applicable regulatory requirements. Implementers of the standard are responsible for observing or referring to the applicable regulatory requirements. IEEE does not, by the publication of its standards, intend to urge action that is not in compliance with applicable laws, and these documents may not be construed as doing so.

Copyrights

IEEE draft and approved standards are copyrighted by IEEE under U.S. and international copyright laws. They are made available by IEEE and are adopted for a wide variety of both public and private uses. These include both use, by reference, in laws and regulations, and use in private self-regulation, standardization, and the promotion of engineering practices and methods. By making these documents available for use and adoption by public authorities and private users, IEEE does not waive any rights in copyright to the documents.

Photocopies

Subject to payment of the appropriate fee, IEEE will grant users a limited, non-exclusive license to photocopy portions of any individual standard for company or organizational internal use or individual, non-commercial use only. To arrange for payment of licensing fees, please contact Copyright Clearance Center, Customer Service, 222 Rosewood Drive, Danvers, MA 01923 USA; +1 978 750 8400. Permission to photocopy portions of any individual standard for educational classroom use can also be obtained through the Copyright Clearance Center.

Updating of IEEE Standards documents

Users of IEEE Standards documents should be aware that these documents may be superseded at any time by the issuance of new editions or may be amended from time to time through the issuance of amendments, corrigenda, or errata. An official IEEE document at any point in time consists of the current edition of the document together with any amendments, corrigenda, or errata then in effect.

Every IEEE standard is subjected to review at least every ten years. When a document is more than ten years old and has not undergone a revision process, it is reasonable to conclude that its contents, although still of some value, do not wholly reflect the present state of the art. Users are cautioned to check to determine that they have the latest edition of any IEEE standard.

In order to determine whether a given document is the current edition and whether it has been amended through the issuance of amendments, corrigenda, or errata, visit the IEEE Xplore at <http://ieeexplore.ieee.org/> or contact IEEE at the address listed previously. For more information about the IEEE-SA or IEEE's standards development process, visit the IEEE SA Website at <http://standards.ieee.org>.

Errata

Errata, if any, for all IEEE standards can be accessed on the IEEE SA Website at the following URL: <http://standards.ieee.org/findstds/errata/index.html>. Users are encouraged to check this URL for errata periodically.

Patents

Attention is called to the possibility that implementation of this standard may require use of subject matter covered by patent rights. By publication of this standard, no position is taken by the IEEE with respect to the existence or validity of any patent rights in connection therewith. If a patent holder or patent applicant has filed a statement of assurance via an Accepted Letter of Assurance, then the statement is listed on the IEEE SA Website at <http://standards.ieee.org/about/sasb/patcom/patents.html>. Letters of Assurance may indicate whether the Submitter is willing or unwilling to grant licenses under patent rights without compensation or under reasonable rates, with reasonable terms and conditions that are demonstrably free of any unfair discrimination to applicants desiring to obtain such licenses.

Essential Patent Claims may exist for which a Letter of Assurance has not been received. The IEEE is not responsible for identifying Essential Patent Claims for which a license may be required, for conducting inquiries into the legal validity or scope of Patents Claims, or determining whether any licensing terms or conditions provided in connection with submission of a Letter of Assurance, if any, or in any licensing agreements are reasonable or non-discriminatory. Users of this standard are expressly advised that determination of the validity of any patent rights, and the risk of infringement of such rights, is entirely their own responsibility. Further information may be obtained from the IEEE Standards Association.

IEEE Introduction

This introduction is not part of IEEE Std 2401-2019, IEEE Standard Format for LSI-Package-Board Interoperable Design.

To deal with the increasing difficulty of design and the cost competitiveness of the global market, and to shorten the development term, innovative design methodologies should be implemented. It has been difficult to achieve the optimization of an entire set of large-scale integration (LSI), package, and board (LPB) using individual design processes for each LPB part.

One possibility for optimization is to have a certain section design the whole LPB; however, gathering knowledge and integrating the design environment of each LPB part is difficult. Dedicated professional technicians of individual LPB parts, who have the best knowledge and performance of their own part's design tools, intend to create design optimization by having proper interoperable information exchanges among all LPB parties. In order to achieve a design that optimizes the balance between cost and performance, information about and the results of design should be well shared among cooperating LPB design sections.

The standard format of LSI package board interoperable design (hereinafter called *LPB Format*) was developed to make it easier to exchange information among LPB design departments, so that optimal design will be carried out quickly.

The LPB interoperable design process has the following issues:

- Netlist not unified on each LPB
- Complexity of the representation of the relationship as a whole arrangement of the LPB
- Differences in how to give the design constraints, lack of design information, and many discrepancies in design rules
- Databases not unified in each LPB, or among different vendors
- No unified terms

Various problems caused by these issues include the following:

- A large effort is required for conversion of formats.
- The occurrence of conversion errors and connection errors is difficult to detect because there is a lack of the information needed to do so.
- It takes a long time to gather information, resulting in a long period of design and analysis.
- It is difficult to make optimal design changes because the entire verification process is difficult.
- Electronic design automation (EDA) tool cost increase because of additional development required to support multiple formats.
- It is time consuming for designers to communicate their intentions in a way that others understand.

Based on this analysis, the interface LPB Format has been developed which can address these issues.

As the one of the case studies of the LPB interoperable design process, the power distribution network (PDN) should be designed with information about the other LPB parts to reduce the noise (see Figure i).

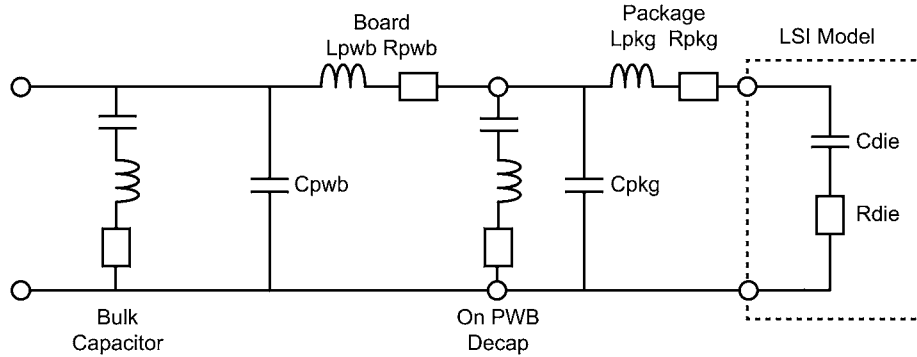

Reprinted with permission from JEITA.

Figure i—Power distribution network

Resonance is caused by a capacitance and inductance present in the various parts in the LPB PDN. Impedance at the resonant frequency will be extremely large. If each part of the overall LPB design is not accurately simulated in the PDN model, the power supply circuit cannot be correctly designed (see Figure ii).

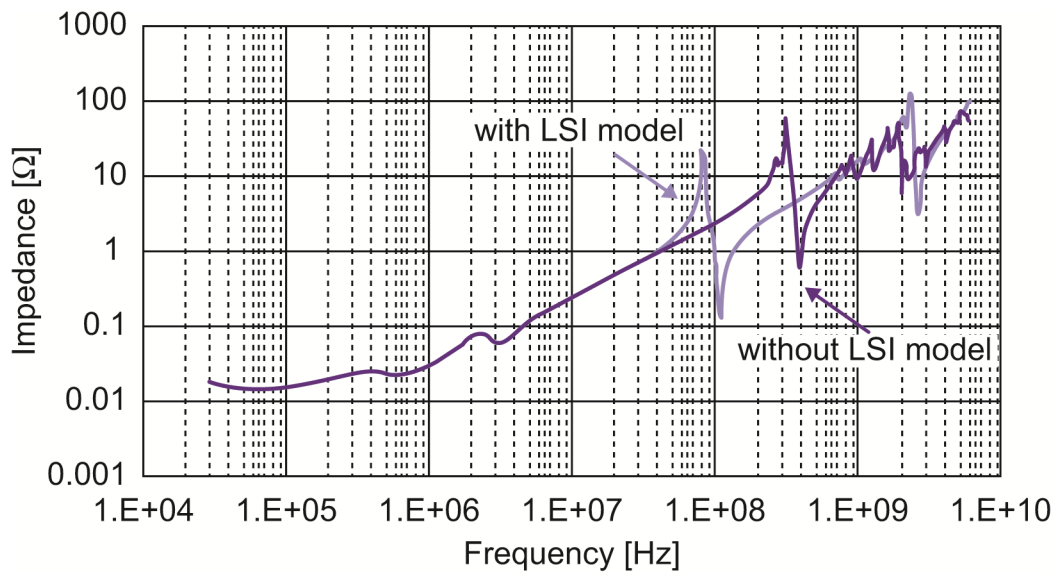

Reprinted with permission from JEITA.

Figure ii—Example of PDN impedance

In order to run properly, this simulation should align a variety of information, such as the circuit model of power distribution network (PDN) of LSI, shape information about the package and board, electrical parameters of materials, and models of the components. It is difficult to make an efficient design when the specification or format of the design information is different in each part of the LPB, and the necessary parameters are not shared. When the format of the interface methods and models of the simulation are not consistent, the setup time and the cost of design/verification are enormous, which has become a barrier to cooperation in LPB design. The LPB Format will be evolved to create a mutual interface to enable a more efficient co-design environment.

IEEE Standard Format for LSI-Package-Board Interoperable Design

1. Overview

1.1 Scope

This standard defines a common interoperable format that will be used for the design of a) large-scale integration (LSI), b) packages for such LSI, and c) printed circuit boards on which the packaged LSIs are interconnected. Collectively, such designs are referred to as *LSI-Package-Board (LPB)* designs. The format provides a common way to specify information/data about the project management, netlists, components, design rules, and geometries used in LPB designs.

1.2 Purpose

The general purpose of this standard is to develop a common format that LPB design tools can use to exchange information/data seamlessly, as opposed to having to work with multiple different input and output formats.

1.3 Key characteristics of the LSI-Package-Board Format

The LPB Format will facilitate the exchange of design information. This functionality provides the ability to plan the entire design at an early stage. In effect, post-design analysis will be possible throughout the entire LPB design process. Analysis of each part of the design can be examined in relation to all other parts of the design to determine the optimal point to give feedback for appropriate design changes throughout the LPB. This will promote the overall optimization of the design process.

The LPB Format is constructed out of the following five formats (see Figure 1):

- a) Project Management (M-Format)
- b) Netlist (N-Format)
- c) Component (C-Format)
- d) Design Rule (R-Format)
- e) Geometry (G-Format)

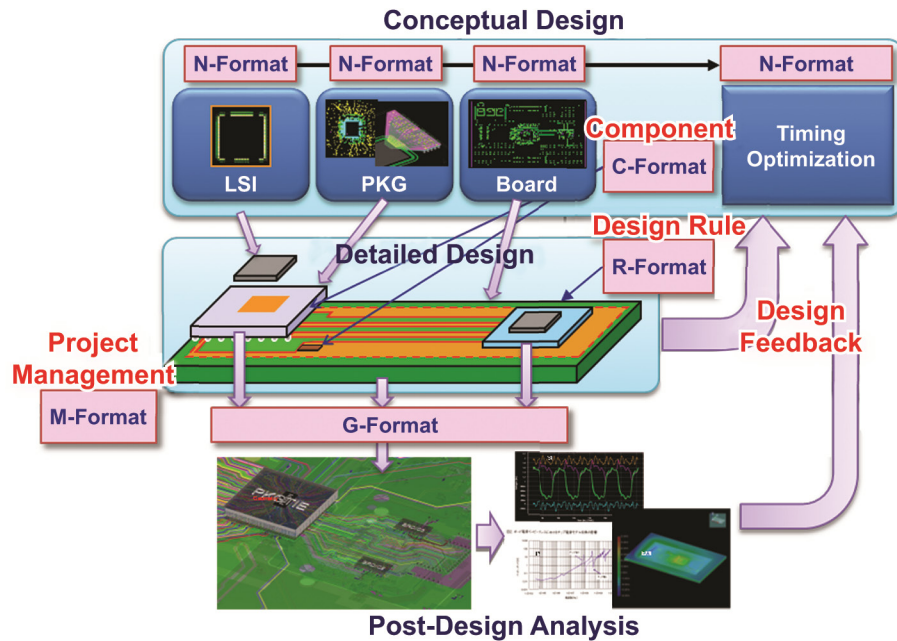

Reprinted with permission from JEITA.

Figure 1—LPB Format

Design time can be shortened by using the LPB Format. Traditionally, design starts immediately after separate planning for each individual component of the LPB. Therefore, information exchange among the separate design processes is limited. Trying to adjust the detailed design of one component to the detailed design of another component makes the entire design period take longer. Optimization also tends to be a separate process for each component of the LPB. By using the LPB Format for distributed information, each LPB engineer will be able to have the same understanding of the challenges at an early stage. As a result, adjustments at the conceptual design stage can be made, before detailed designs are developed. By making clear the overall LPB product specifications, the design target can be decided, and so the duration of individual designs can be shortened. Use of the LPB Format also helps to reduce the number of design iterations, because the design quality is enhanced. The designers can collect all information for simulation using the LPB formats, thereby reducing production time. The LPB Format can enable the entire analysis easily, so that sufficient verification can be done and the quality of the products can be improved. As a result, the period of adjustment in the set can be shortened and the time to market can be accelerated. With the LPB Format, the design method for one product can be applied to the design environment for next product in development.

1.4 Contents of this standard

The organization of the remainder of this standard is as follows:

- Clause 2 provides references to other applicable standards that are presumed or required for this standard.
- Clause 3 defines terms and acronyms used throughout the different specifications contained in this standard.
- Clause 4 describes the concepts of the LPB Format.
- Clause 5 describes the language basics for the LPB Format and its commands.
- Clause 6 describes common elements in the M-Format, C-Format, and R-Format.

- Clause 7 describes the M-Format.
- Clause 8 describes the C-Format.
- Clause 9 describes the R-Format.
- Clause 10 describes the N-Format.
- Clause 11 describes the G-Format.

1.5 Word usage

The word *shall* indicates mandatory requirements strictly to be followed in order to conform to the standard and from which no deviation is permitted (shall equals is required to).^{1, 2}

The word *should* indicates that among several possibilities one is recommended as particularly suitable, without mentioning or excluding others; or that a certain course of action is preferred but not necessarily required (should equals is recommended that).

The word *may* is used to indicate a course of action permissible within the limits of the standard (may equals is permitted to).

The word *can* is used for statements of possibility and capability, whether material, physical, or causal (can equals is able to).

2. Normative references

The following referenced documents are indispensable for the application of this document (i.e., they must be understood and used, so each referenced document is cited in text and its relationship to this document is explained). For dated references, only the edition cited applies. For undated references, the latest edition of the referenced document (including any amendments or corrigenda) applies.

IEEE Std 1364™, IEEE Standard for Verilog® Hardware Description Language.^{3, 4}

¹ The use of the word *must* is deprecated and cannot be used when stating mandatory requirements; *must* is used only to describe unavoidable situations.

² The use of *will* is deprecated and cannot be used when stating mandatory requirements; *will* is only used in statements of fact.

³ IEEE publications are available from The Institute of Electrical and Electronics Engineers (<http://standards.ieee.org/>).

⁴ The IEEE standards or products referred to in this clause are trademarks of The Institute of Electrical and Electronics Engineers, Inc.